

SAMPLE PAGES FOR

The Competitive Edge Algebra I EOC Test ALGEBRA I END-OF-COURSE

J A N E H E R E F O R D

TABLE OF CONTENTS

	North Carolina Course of Study for Algebra I	v
1	Whole Numbers	1
2	Decimals	19
3	Fractions	29
4	Percents	51
5	Tables and Graphs	67
6	Data Display	77
7	Two-Dimensional Figures and Area	82
8	Perimeter	93
9	Surface Area	98
10	Volume	104
11	Circumference of Circle	108
12	Mean, Median, Mode and Range	112
13	Number Lines and Absolute Value	124
14	Rational Numbers and Square Roots	131
15	Properties	143
16	Algebraic Expressions and Order of Operations	149
17	Simple Equations and Inequalities	157
18	Two-Step Equations and Inequalities	173
19	Ratios and Proportions	186
20	Coordinate Planes	199
21	Linear Equations	218
22	Sequences	239
23	Systems of Linear Equations	245
24	Polynomials	256
25	Factoring	274
26	Quadratic Functions and Equations	292
27	Radical Expressions and Triangles	311
28	Rational Expressions	324
29	Statistics	339
30	Probability	357

21 || CHAPTER

LINEAR EQUATIONS

➤ *Equations as Relations*

A **solution** is an ordered pair that when substituted into an equation with two variables results in a true statement.

USING A REPLACEMENT SET

EXAMPLE

Find the solution set for $y = 3x + 2$. Use the replacement set $\{(-4, -3), (-3, 5), (2, 8)\}$.

x	y	$y = 3x + 2$	True/False
-4	-3	$-3 = 3(-4) + 2$ $-3 \neq -10$	False
-3	5	$5 = 3(-3) + 2$ $5 \neq -7$	False
2	8	$8 = 3(2) + 2$ $8 = 8$	True

Make a table and substitute each ordered pair into the equation.

$(2, 8)$ results in a true statement.

The solution set is $\{(2, 8)\}$.

USING A DOMAIN

EXAMPLE

Find the solution set for $w = t + 4$ if the domain is $\{-2, -1, 0, 1, 2\}$.

(*Remember that the domain is the letter that comes first in the alphabet!)

t	$t + 4$	w	(t,w)
-2	$-2 + 4$	2	$(-2, 2)$
-1	$-1 + 4$	3	$(-1, 3)$
0	$0 + 4$	4	$(0, 4)$
1	$1 + 4$	5	$(1, 5)$
2	$2 + 4$	6	$(2, 6)$

Make a table. t is the domain, so substitute each domain value for t into the equation to determine the values of the range (w).

The solution set is $\{(-2, 2), (-1, 3), (0, 4), (1, 5), (2, 6)\}$.

USING A SOLUTION SET TO SOLVE AND GRAPH

EXAMPLE

Solve $2a + 4b = -20$ if the domain is $\{-3, -2, -1, 0\}$. Graph the solution set.

$$2a + 4b = -20$$

Solve the equation for b in terms of a .

$$2a - 2a + 4b = -20 - 2a$$

Subtract $2a$ from each side.

$$4b = -20 - 2a$$

$$\frac{4b}{4} = \frac{-20 - 2a}{4}$$

$$b = -5 - \frac{1}{2}a$$

Simplify.
Divide each side by 4.

Simplify.

a	$-5 - \frac{1}{2}a$	b	(a, b)
-3	$-5 - \frac{1}{2}(-3)$	-3.5	(-3, -3.5)
-2	$-5 - \frac{1}{2}(-2)$	-4	(-2, -4)
-1	$-5 - \frac{1}{2}(-1)$	-4.5	(-1, -4.5)
0	$-5 - \frac{1}{2}(0)$	-5	(0, -5)

The solution set is $\{(-3, -3.5), (-2, -4), (-1, -4.5), (0, -5)\}$.

Graph the solution set.

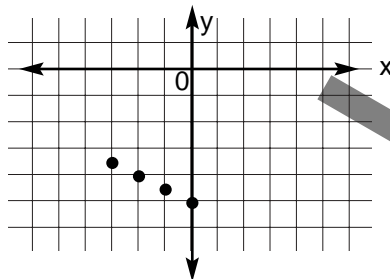

➤ Graphing Linear Equations

An equation that is linear has a graph that is a straight line.

EXAMPLE

$$y = x - 1$$

x	$x - 1$	y
-1	$(-1) - 1$	-2
0	$(0) - 1$	-1
1	$(1) - 1$	0
2	$(2) - 1$	1
3	$(3) - 1$	2

Make a chart as shown on the left. Choose any 5 values for x (Smaller numbers are best.), then solve for y.

Now graph using the x, y columns for your ordered pairs.

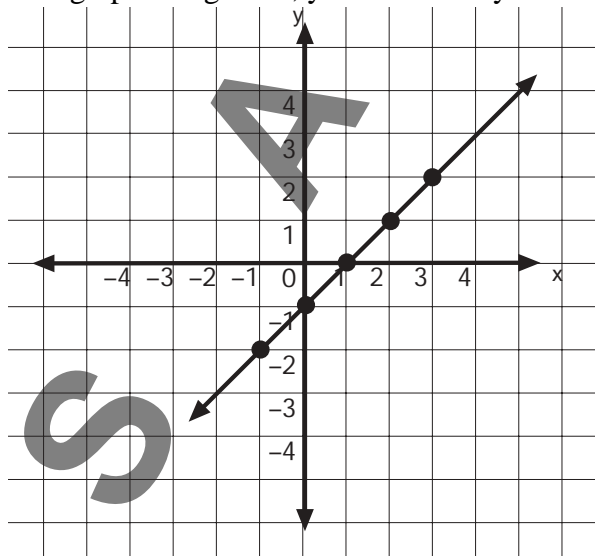

Connect your points.

You have a straight line!

PRACTICE

Find the solution set for each equation given the replacement set.

1. $y = 4x + 5$
 $\{(-1, 0), (2, 13), (3, -15), 4, 21)\}$

2. $-2x + 3y = 3$
 $\{(0, 3), (1, 1), (2, -3), (3, 3)\}$

Solve each equation using the domain $\{-2, -1, 0, 1\}$.

3. $y = 4x - 3$

4. $2x + 3y = 15$

Solve each equation using the given domain. Graph the solution set.

5. $y = 4x$ domain = $\{-2, -1, 0, 1, 2, 3, 4\}$

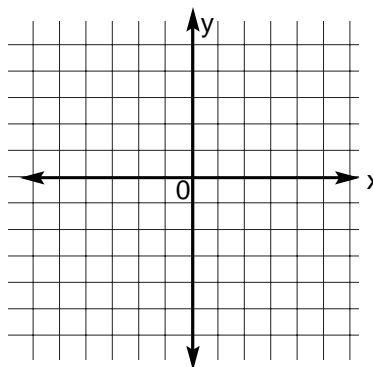

6. $3y = 3x + 6$ domain = $\{-6, -4, -2, 0, 2, 4\}$

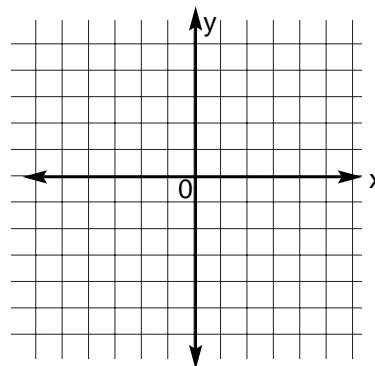

Choose 5 values for x .
Use the chart to find the values of y .

7. $y = 2x$

x	$2x$	y

11. $y = 5 - x$

x	$5 - x$	y

15. $y = 4 - \frac{1}{2}x$

x	$4 - \frac{1}{2}x$	y

8. $y = x - 1$

x	$x - 1$	y

12. $y = 4x - 2$

x	$4x - 2$	y

16. $y = 2x + 6$

x	$2x + 6$	y

9. $y = 3x + 1$

x	$3x + 1$	y

13. $y = 6 - 2x$

x	$6 - 2x$	y

17. $y = \frac{1}{4}x + 2$

x	$\frac{1}{4}x + 2$	y

10. $y = 2x - 1$

x	$2x - 1$	y

14. $y = x - 6$

x	$x - 6$	y

18. $y = x - \frac{1}{2}$

x	$x - \frac{1}{2}$	y

➤ Slope

Slope is the steepness of a line. It is expressed as the ratio of the change in y (vertical change) and the change in x (horizontal change) between any two points on the line.

$$\text{Slope} = \frac{\text{change in } y - \text{variable (vertical change)}}{\text{change in } x - \text{variable (horizontal change)}} \quad m = \frac{y_2 - y_1}{x_2 - x_1} \begin{matrix} \text{(rise)} \\ \text{(run)} \end{matrix}$$

EXAMPLES

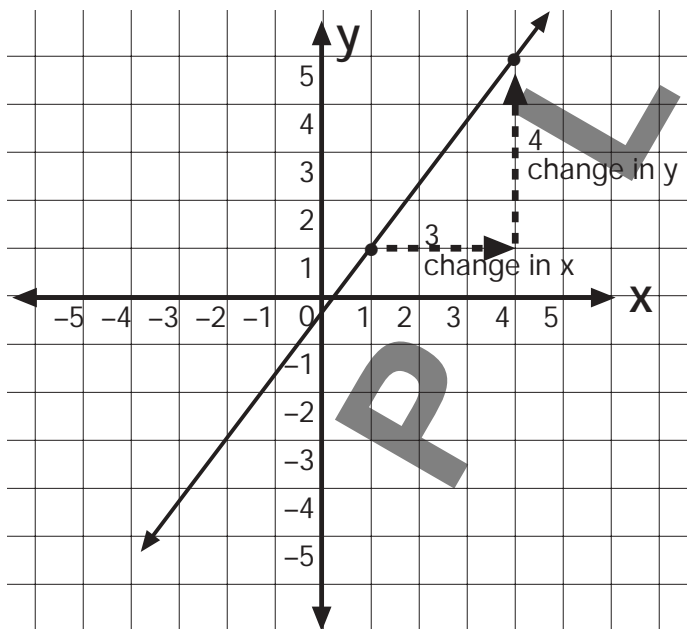

The change in y is 4, and the change of x is 3. The slope of the line is $\frac{4}{3}$.

The slope of a line can also be determined from the coordinates of any two points on a line. It does not matter which point you define as (x_1, y_1) or (x_2, y_2) .

$$\text{Slope} = \frac{\text{difference of } y - \text{coordinate}}{\text{difference of } x - \text{coordinate}} \quad m = \frac{y_2 - y_1}{x_2 - x_1} \begin{matrix} \text{(rise)} \\ \text{(run)} \end{matrix}$$

POSITIVE SLOPE

A graph of a line with a positive slope slopes up from left to right.

EXAMPLE

Find the slope of the line that contains points $(1, -1)$ and $(-2, -5)$.

$$m = \frac{y_2 - y_1}{x_2 - x_1} \begin{matrix} \text{(rise)} \\ \text{(run)} \end{matrix} \quad m = \frac{-1 - (-5)}{1 - (-2)} = \frac{4}{3}$$

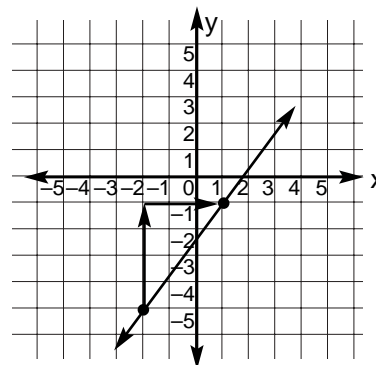

NEGATIVE SLOPE

A graph of a line with a negative slope, slopes down from left to right.

EXAMPLE

Find the slope of a line that contains points $(-2, -3)$ and $(-5, 2)$.

$$m = \frac{y_2 - y_1}{x_2 - x_1} \quad \left(\frac{\text{rise}}{\text{run}} \right) \quad m = \frac{2 - (-3)}{-5 - (-2)} = \frac{5}{-3}$$

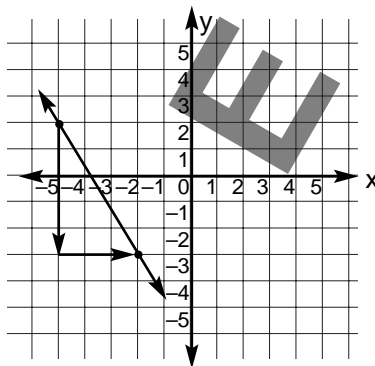

ZERO SLOPE

A graph of a line with a zero slope has a horizontal line.

EXAMPLE

Find the slope of a line that contains points $(2, 3)$ and $(-2, 3)$.

$$m = \frac{y_2 - y_1}{x_2 - x_1} \quad \left(\frac{\text{rise}}{\text{run}} \right) \quad m = \frac{3 - 3}{-2 - 2} = \frac{0}{-4} = 0$$

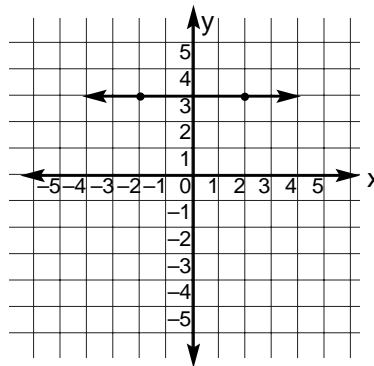

UNDEFINED SLOPE

The graph of a line with an undefined slope is a vertical line.

EXAMPLE

Find the slope of a line that contains points $(2, -3)$ and $(2, 4)$.

$$m = \frac{y_2 - y_1}{x_2 - x_1} \quad \left(\frac{\text{rise}}{\text{run}} \right) \quad m = \frac{4 - (-3)}{2 - 2} = \frac{7}{0}$$

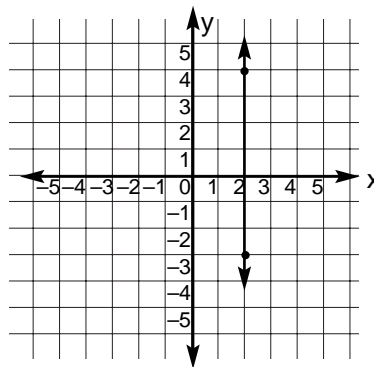

Division by zero is undefined, so the slope is also undefined.

PRACTICE

Find the slope of each line. Determine if it's positive, negative, zero, or undefined.

1.

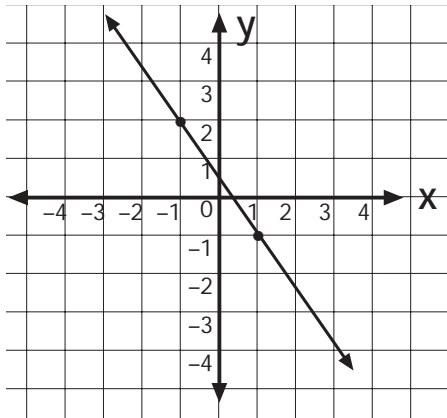

2.

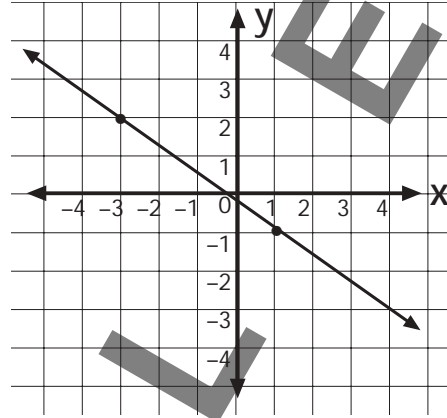

3.

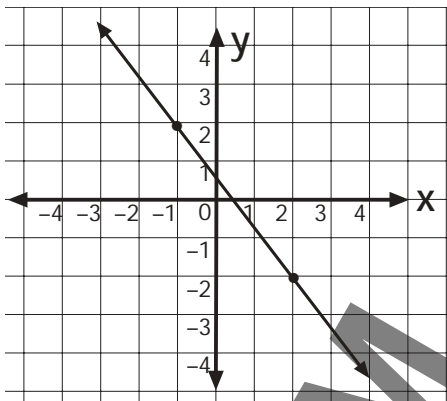

4.

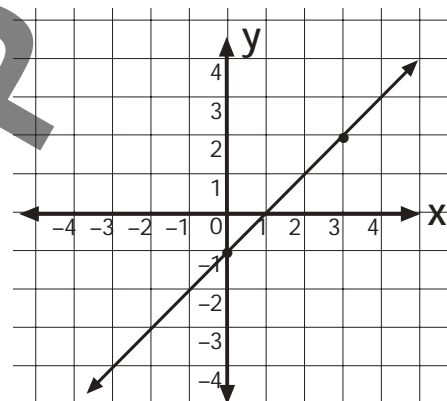

S

A

Find the slope of the line that contains each pair of points.

Determine if it's positive, negative, zero or undefined.

5. A (2, 3), B (-1, 6) _____

6. C (5, -2), D (4, -3) _____

7. E (0, 8), F (2, 1) _____

8. G (-3, 1), H (4, 5) _____

9. I (-1, 1), J (3, -4) _____

10. K (4, 1), L (3, -2) _____

11. M (-4, -4), N, (-4, 2) _____

12. O (-3, 7), P (1, -2) _____

13. Q (0, -6), R (2, -5) _____

14. S (-5, 1), T (3, 1) _____

15. U (5, 3), V (-1, 1) _____

➤ Intercepts

Points of intersection can be used to graph a line. Each line below intercepts the x-axis in one point and the y-axis in one point.

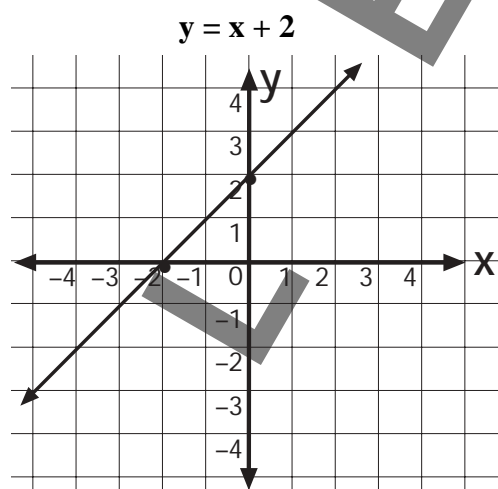
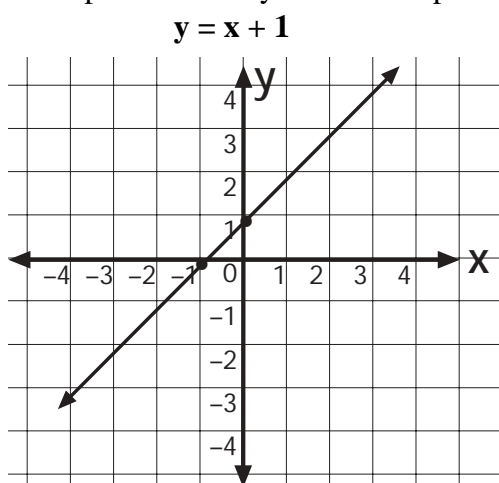

Equation	Point of intersection y-axis	y-intercept	Point of intersection x-axis	x-intercept
$y = x + 1$	(0, 1)	1	(-1, 0)	-1
$y = x + 2$	(0, 2)	2	(-2, 0)	-2

EXAMPLE

Find the x-intercept and y-intercept for $y = x + 9$.

- Find the x-intercept.

Let $y = 0$ and solve for x .

$$0 = x + 9$$

$$-9 = x$$

The x-intercept is -9 .

The ordered pair is $(-9, 0)$.

- Find the y-intercept.

Let $x = 0$ and solve for y .

$$y = 0 + 9$$

$$y = 9$$

The y-intercept is 9 .

The ordered pair is $(0, 9)$.

S

PRACTICE

Find the x-intercept and y-intercept for each equation.

1. $y = 7x - 2$

9. $y = 3x + 1$

2. $y = 4 + x$

10. $y = x - 3$

3. $y = \frac{x}{2} - 5$

11. $y = x - 8$

4. $y = 3x + 5$

12. $y = 5x + 6$

5. $y = 5 + 2x$

13. $y = 2x - 3$

6. $y = x - 2$

14. $y = x + 1$

7. $y = x + 3$

15. $y = 3x - 1$

8. $y = \frac{x}{4} - 2$

➤ *Slope-Intercept Form*

$y = mx + b$ is called the slope intercept form, where m is the slope, and b is the y -intercept.

IDENTIFYING SLOPE AND Y-INTERCEPT

EXAMPLE

Find the slope and y -intercept.

Slope intercept form: $y = \mathbf{m}x + \mathbf{b}$
slope y -intercept

Equation: $y = \frac{1}{3}x + 4$

$m = \frac{1}{3}$ $b = 4$

slope = $\frac{1}{3}$ y -intercept = 4

WRITING AN EQUATION IN SLOPE-INTERCEPT FORM

EXAMPLE

Write $y - 4 = \frac{1}{4}(x + 2)$ in slope-intercept form. ($y = mx + b$)

$y - 4 = \frac{1}{4}(x + 2)$ Solve for y .

$y - 4 = \frac{1}{4}x + \frac{1}{2}$ Multiply $\frac{1}{4}(x + \frac{1}{2})$.

$y - 4 + 4 = \frac{1}{4}x + \frac{1}{2} + 4$ Add 4 to each side.

$y = \frac{1}{4}x + 4\frac{1}{2}$ Simplify.

The equation in slope-intercept form ($y = mx + b$) is $y = \frac{1}{4}x + 4\frac{1}{2}$.

WRITING AN EQUATION USING SLOPE AND Y-INTERCEPT

EXAMPLE

Write an equation of the line with slope $\frac{3}{4}$ and y -intercept 8.

$y = mx + b$ (slope-intercept form)

Substitute $\frac{3}{4}$ for m and 8 for b .

$y = \frac{3}{4}x + 8$ is the equation in slope-intercept form.



WRITING AN EQUATION FROM A GRAPH

EXAMPLE

Write the equation for the line in the graph.

Find the slope when two points on a line are (2, 2) and (0, 4).

$$\text{slope} = \frac{y_2 - y_1}{x_2 - x_1} \left(\frac{\text{rise}}{\text{run}} \right) = \frac{4 - 2}{0 - 2} = \frac{2}{-2} = -1$$

The slope is -1 .

The y-intercept is 4 because the line crosses the x-axis at (0, 4).

$y = mx + b$ (slope-intercept form)

$y = -x + 4$ is the equation for this line in slope-intercept form.

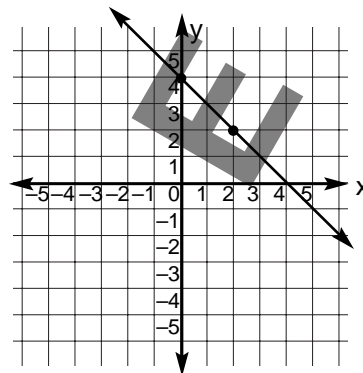

EXAMPLE

Write the equation for the line in the graph.

The line on the graph has a slope (m) of 4 and passes through (4, -2).

$y = mx + b$ (slope-intercept form)

$$-2 = 4(4) + b$$

Replace m with 4, y with -2 and x with 4.

$$-2 = 16 + b$$

Multiply.

$$-2 + 2 = 16 + b + 2$$

Add 2 to each side.

$$0 = b + 18$$

$$0 - 18 = b + 18 - 18$$

Subtract 18 from each side.

$$-18 = b$$

Simplify.

Now write the equation in slope-intercept form.

$y = mx + b$ (slope-intercept form)

$y = 4x - 18$ Replace m with 4 and b with -18 .

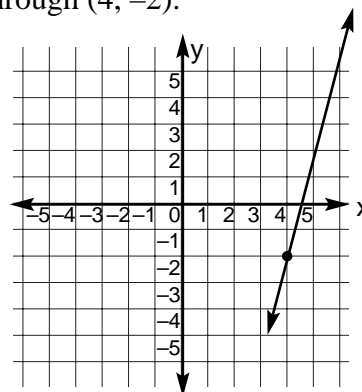

WRITING EQUATIONS IN POINT-SLOPE FORM

The point-slope form is an equation made by using the coordinates of a known point and the slope of the line.

linear equation in point-slope form $y - y_1 = m(x - x_1)$

(x_1, y_1) = given point

m = slope of the line

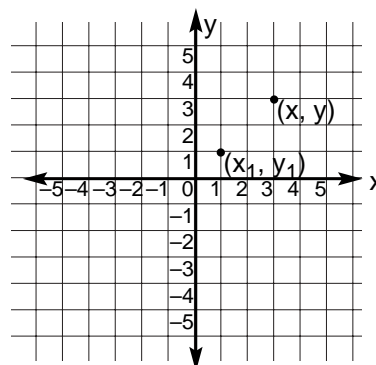

WRITING AN EQUATION USING SLOPE AND POINT

EXAMPLE

Write the point-slope form of an equation for a line that passes through $(-3, 2)$ with a slope -2 .

$$y - y_1 = m(x - x_1) \quad (\text{point-slope form})$$

$$y - 2 = -2[x - (-3)] \quad (x_1, y_1) = (-3, 2)$$

$$y - 2 = -2(x + 3) \quad \text{Simplify.}$$

The equation is $y - 2 = -2(x + 3)$.

WRITING AN EQUATION OF A HORIZONTAL LINE

EXAMPLE

Write the point-slope form of an equation for a horizontal line that passes through $(4, -4)$.

(Slope = 0 since it is a horizontal line.)

$$y - y_1 = m(x - x_1) \quad (\text{point-slope form})$$

$$y - (-4) = 0(x - 4) \quad (x_1, y_1) = (4, -4)$$

$$y + 4 = 0 \quad \text{Simplify.}$$

The equation is $y + 4 = 0$.

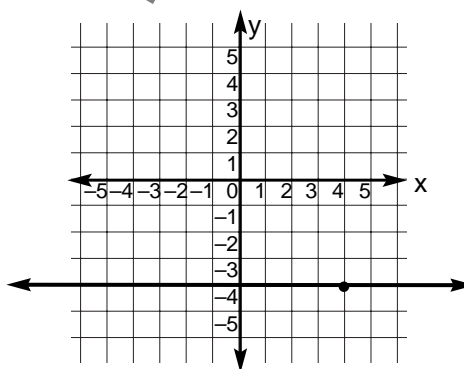

Vertical lines cannot be written in point-slope form since their slope is undefined.

WRITING AN EQUATION IN STANDARD FORM

Write $y + 6 = -\frac{3}{4}(x - 3)$ in standard form. In standard form, all variables are on the left side of the equation.

$$y + 6 = -\frac{3}{4}(x - 3)$$

$$4(y + 6) = 4\left(-\frac{3}{4}\right)(x - 3) \quad \text{Multiply each side by 4.}$$

$$4y + 24 = -3(x - 3) \quad \text{Use distributive property.}$$

$$4y + 24 = -3x + 9 \quad \text{Use distributive property.}$$

$$4y + 24 - 24 = -3x + 9 - 24 \quad \text{Subtract 24 from each side.}$$

$$4y = -3x - 15 \quad \text{Simplify.}$$

$$4y + 3x = -3x - 15 + 3x \quad \text{Add 3x to each side.}$$

$$3x + 4y = -15 \quad \text{Simplify.}$$

The standard form of the equation is $3x + 4y = -15$.



➤ Graphing an Equation

EXAMPLE

Graph $y = \frac{1}{2}x - 2$ ($y = mx + b$)

slope = $\frac{1}{2}$ y-intercept = -2

Graph the y-intercept $(0, -2)$.

Find a second point by using the slope.

1 change in y, up 1 unit

2 change in x, right 2 units

Second point $(2, -1)$

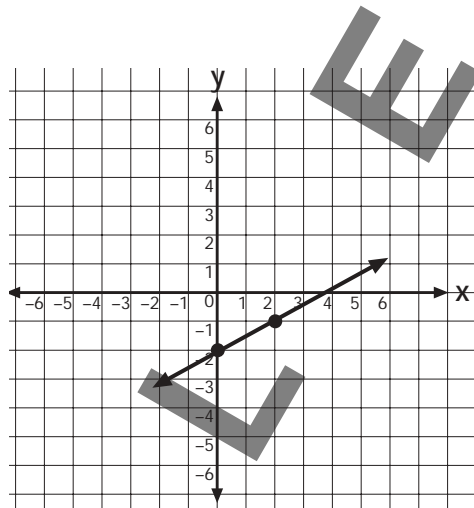

PRACTICE

State the slope and y-intercept for each.

1. $y = \frac{1}{3}x + 4$

4. $y = 2x + 1$

2. $y = -4x - 2$

5. $y = \frac{1}{2}x + 2$

3. $y = \frac{3}{8}x - \frac{1}{2}$

6. $y = -x + 15$

Write an equation for each.

7. slope = 1 y-intercept = 3

10. slope = $-\frac{1}{5}$ y-intercept = 7

8. slope = 3 y-intercept = -5

11. slope = 3 y-intercept = 2

9. slope = $-\frac{1}{8}$ y-intercept = -3

12. slope = -1 y-intercept = 4

(continued on next page)

Graph each equation using the slope and y-intercept.

13. $y = \frac{2}{3}x - 4$

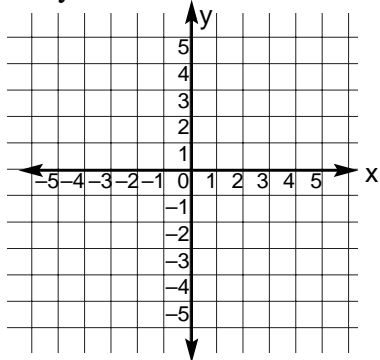

15. $y = \frac{1}{3}x - 2$

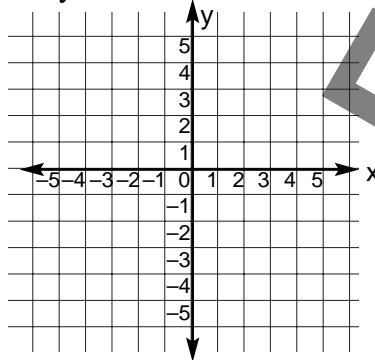

14. $y = -3x + 2$

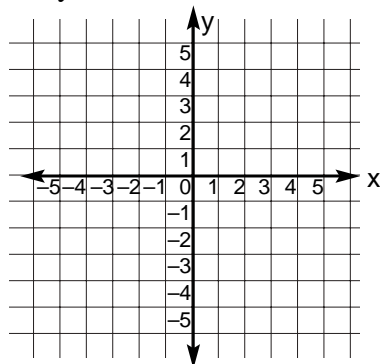

Graph the line for each set of points.
Write an equation in slope-intercept form from each graph.

16. $(1, 0)$ $(3, -1)$

17. $(0, 1)$ $(3, 2)$

18. Write the point-slope form of an equation for a line that passes through $(4, 9)$, $m = 2$.

19. Write the point-slope form of an equation for a line that passes through $(-5, 0)$, $m = -4$.

20. Write the point-slope form of an equation for a line that passes through $(7, -4)$, $m = \frac{3}{4}$.

21. Write the point-slope form of an equation for a horizontal line that passes through $(6, -8)$.

22. Write the point-slope form of an equation for a horizontal line that passes through $(1, 8)$.

Write each equation in standard form.

23. $y - 4 = -3(x + 2)$

25. $y + 3 = -\frac{1}{2}(x - 11)$

24. $y - 2 = -\frac{4}{5}(x - 2)$

26. $y + 6 = \frac{1}{6}(x - 3)$

➤ *Parallel and Perpendicular Lines*

PARALLEL LINES

Parallel lines are lines that are in the same plane that never intersect.

The equation of the broken line is $y = \frac{1}{4}x + 2$.

The equation of the solid line is $y = \frac{1}{4}x + 1$.

Same slope $\Rightarrow \frac{1}{4}$

Different y-intercepts $\Rightarrow 2$ and 1

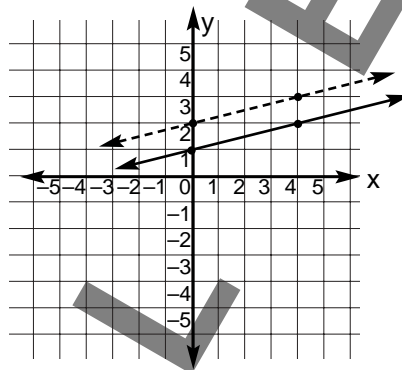

Non-vertical lines are parallel if they have the same slopes but different y-intercepts.
All vertical lines are parallel.

ARE THESE LINES PARALLEL?

EXAMPLE

Are the graphs of $y = -\frac{1}{6}x + 3$ and $2x + 12y = 24$ parallel?

$y = -\frac{1}{6}x + 3$ is in slope-intercept form ($y = mx + b$).

$2x + 12y = 24$ You must change this into slope-intercept form.

$$2x - 2x + 12y = -2x + 24$$

Subtract $2x$ from each side.

$$12y = -2x + 24$$

Simplify.

$$\frac{12y}{12} = \frac{-2x + 24}{12}$$

Divide each side by 12 .

$$y = -\frac{1}{6}x + 2$$

Simplify.

These lines are parallel because both equations ($y = -\frac{1}{6}x + 3$ and $y = -\frac{1}{6}x + 2$) have the same slope ($-\frac{1}{6}$) and different y-intercepts (3 and 2).

WRITING EQUATIONS FOR PARALLEL LINES

EXAMPLE

Write an equation in slope-intercept form for the line that contains $(8, 2)$ and is parallel to $y = \frac{1}{2}x - 1$. (To be parallel lines, the lines must have the same slope.)

$$y - y_1 = m(x - x_1) \quad \text{Point-slope form}$$

$$y - 2 = \frac{1}{2}(x - 8)$$

Replace m with $\frac{1}{2}$, x_1 with 8 and y_1 with 2 .

$$y - 2 = \frac{1}{2}x - 4$$

Use distributive property.

$$y - 2 + 2 = \frac{1}{2}x - 4 + 2$$

Add 2 to each side.

$$y = \frac{1}{2}x - 2$$

Simplify.

$y = \frac{1}{2}x - 2$ is the equation in slope-intercept form.

PERPENDICULAR LINES

Perpendicular lines are two lines that intersect to form right angles. The product of their slopes is -1 .

The graph shows the intersection of two lines ($y = -\frac{1}{2}x - 1$ and $y = 2x + 2$) that are perpendicular. The slope of $y = -\frac{1}{2}x - 1$ is $-\frac{1}{2}$. The slope of $y = 2x + 2$ is 2 . Since $-\frac{1}{2} \cdot 2 = -1$, the graphs of the two equations are perpendicular.

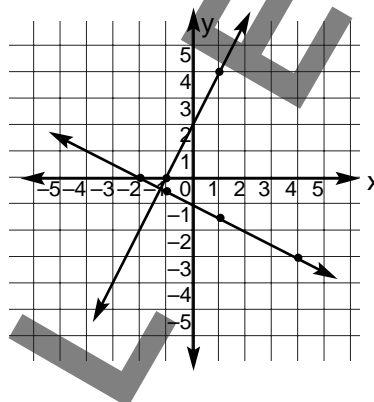

If the product of two numbers is -1 , then one number is the negative-reciprocal of the other.

EXAMPLES

$$-\frac{3}{4} \quad -\frac{3}{4} \cdot \frac{4}{3} = -1 \quad \frac{4}{3} \text{ is the negative reciprocal of } -\frac{3}{4}.$$

$$\frac{5}{3} \quad \frac{5}{3} \cdot -\frac{3}{5} = -1 \quad -\frac{3}{5} \text{ is the negative reciprocal of } \frac{5}{3}.$$

WRITING EQUATIONS FOR PERPENDICULAR LINES

EXAMPLE

Find the slope-intercept form for an equation of a line containing $(1, -1)$ and that is perpendicular to $y = 4x + 2$.

$$y = mx + b \text{ (slope-intercept form)}$$

$$\text{slope} = m = 4$$

$$\text{negative reciprocal of slope} = -\frac{1}{4}$$

Now use the point-slope form to find the equation.

$$y - y_1 = m(x - x_1) \quad \text{(point-slope form)}$$

$$y - (-1) = -\frac{1}{4}(x - 1) \quad (x_1, y_1) = (1, -1), m = -\frac{1}{4}$$

$$y + 1 = -\frac{1}{4}x + \frac{1}{4} \quad \text{Use distributive property.}$$

$$y + 1 - 1 = -\frac{1}{4}x + \frac{1}{4} - 1 \quad \text{Subtract 1 from each side.}$$

$$y = -\frac{1}{4}x - \frac{3}{4} \quad \text{Simplify.}$$

The equation is $y = -\frac{1}{4}x - \frac{3}{4}$.

PRACTICE

Are the graphs of the lines in each pair parallel?

1. $y = 3x$
 $-21x + 7y = 14$ _____

2. $y = -\frac{1}{3}x + 3$
 $-x - 3y = 6$ _____

3. $y = \frac{1}{4}x + 2$
 $24x + 3y = 12$ _____

Write an equation in slope-intercept form for the line that is parallel to the line given and that passes through the point given.

4. $y = 4x + 3$ (1, 1)

5. $y = \frac{1}{4}x + 3$ (-3, -5)

6. $y = -3x + 2$ (-4, 6)

Write an equation in slope-intercept form for the line that is perpendicular to the line given and that passes through the point given.

7. $y = 3x + 4$ (2, 2)

8. $y = x - 2$ (5, 7)

9. $3x - 2y = 8$ (7, -3)

10. $-9x + 7y = 2$ (14, 11)

➤ Review

1. What is the slope of this line?

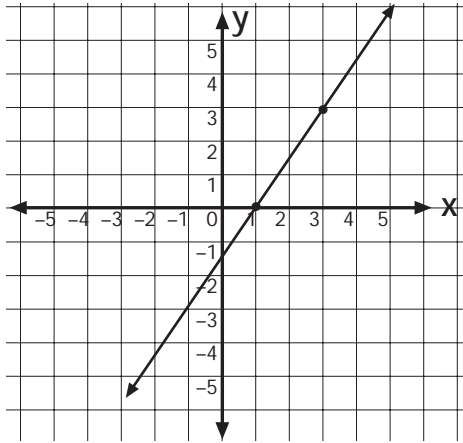

- a. $\frac{2}{3}$
 b. $\frac{1}{1}$
 c. $\frac{3}{2}$
 d. $\frac{2}{4}$

2. Find the x-intercept of $y = x + 4.5$.

- a. (4.5, 0)
 b. (0, 4.5)
 c. (0, -4.5)
 d. (-4.5, 0)

3. Find the slope of the line that contains A (2, 5), B (0, 1).

- a. $\frac{2}{1}$
 b. $\frac{1}{2}$
 c. $\frac{3}{1}$
 d. $\frac{1}{3}$

4. Find the y-intercept of $y = 2x + 3$.

- a. (3, 0)
 b. (0, 5)
 c. (5, 0)
 d. (0, 3)

5. Find the slope of this line.

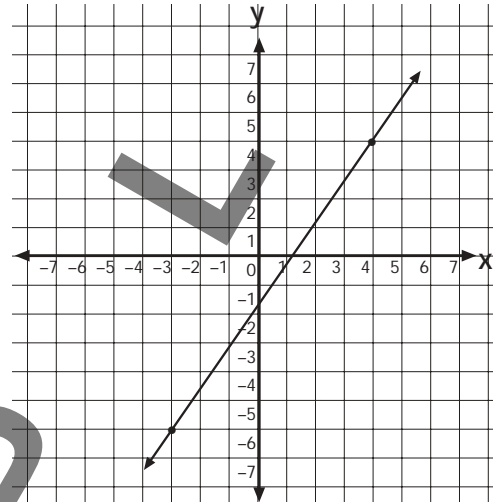

- a. $\frac{7}{10}$
 b. $\frac{3}{2}$
 c. $\frac{10}{7}$
 d. $\frac{2}{3}$

6. Find the slope of the line that contains x (3, 3.5), y (5, 5.5).

- a. $\frac{1}{1}$
 b. $\frac{2.5}{2}$
 c. $\frac{1}{2.5}$
 d. $\frac{2}{2.5}$

7. Find the x-intercept of $y = 3x - 2$.
- $(0, \frac{2}{3})$
 - $(-2, 0)$
 - $(\frac{2}{3}, 0)$
 - $(0, -2)$
8. Find the y-intercept of $y = 2x - 1$.
- $(-1, 0)$
 - $(\frac{1}{2}, 0)$
 - $(0, \frac{1}{2})$
 - $(0, -1)$
9. Which of the following is the correct slope for C (3, 2), D (9, 1)?
- $\frac{-6}{1}$
 - $\frac{4}{1}$
 - $\frac{1}{-4}$
 - $\frac{1}{-6}$
10. Which of the following has (3, 0) as the x-intercept?
- $y = x - 3$
 - $y = x + 3$
 - $y = 2x + 3$
 - $y = x - 5$
11. Which of the following has (0, 2) as the y-intercept?
- $y = x - 2$
 - $y = 2x + 1$
 - $y = x + 2$
 - $y = 2x - 1$

12. What is the slope of this line?

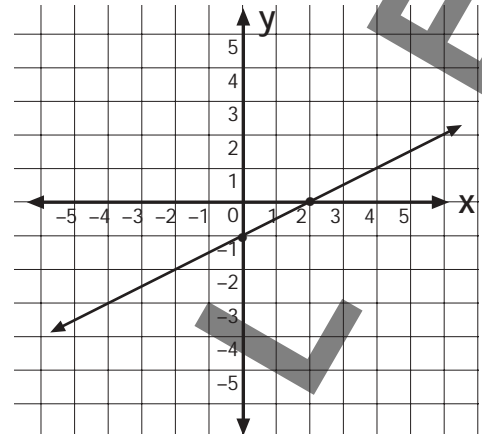

- $\frac{2}{1}$
 - $\frac{1}{2}$
 - $-\frac{1}{2}$
 - $-\frac{2}{1}$
13. Solve.
- $$y = -2x + 4$$
- $$y = -2x + 4$$
- $(-2, -1)$
 - $(2, 1)$
 - no solution
 - $(-2, 1)$
14. Is (1, 3) the ordered pair of the system of equations?
- $$y = x + 2$$
- $$y = 3x$$
- yes
 - no

15. State the equation of a line with a slope of $\frac{1}{9}$ and a y-intercept of 4.

- a. $y = 9x - 4$
- b. $y = -\frac{1}{9}x + 4$
- c. $y = \frac{1}{9}x + 4$
- d. $y = -\frac{1}{9}x - 4$

16. Write the slope-intercept form of the equation for this line.

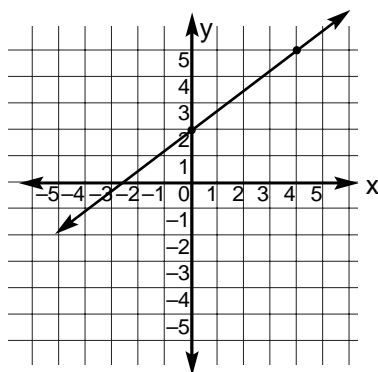

- a. $y = -\frac{3}{4}x + 2$
- b. $y = -\frac{3}{4}x - 2$
- c. $y = \frac{3}{4}x + 2$
- d. $y = \frac{3}{4}x - 2$

17. State the slope for $y = \frac{2}{3}x - 5$.

- a. -5
- b. $\frac{2}{3}$
- c. 3
- d. $\frac{2}{3}x - 5$

18. State the y-intercept for $y = 2x + 4$.

- a. 4
- b. 2
- c. $2x + 4$
- d. 1

19. Write the slope-intercept form of $y = x - 2$ that passes through $(2, -7)$ and is parallel to the graph of the equation.

- a. $y = \frac{1}{2}x + 2$
- b. $y = -x + 9$
- c. $y = -\frac{1}{2}x - 2$
- d. $y = x - 9$

20. Write the slope-intercept form of $3y + 7 = 2x$ that passes through $(3, -3)$ and is perpendicular to the graph of the equation.

- a. $y = -\frac{2}{3}x + 1\frac{1}{2}$
- b. $y = -\frac{3}{2}x + 1\frac{1}{2}$
- c. $y = \frac{1}{3}x + 2\frac{1}{2}$
- d. $y = 3x + 5$

21. $3y = 2x - 2$
 $2x - 3y = 2$

Is the graph of the equation perpendicular, parallel, vertical lines or neither?

- a. parallel
- b. perpendicular
- c. neither
- d. vertical lines

22. $y = 5x$
 $y = -5x + 7$

Is the graph of the equation perpendicular, parallel, vertical lines or neither?

- a. perpendicular
- b. parallel
- c. neither
- d. vertical lines